

Sustained performance



The Cuthbert Heath Award
2013 Winner
For excellence in claims service

Premier Partner of  BRITISH FENCING

Sustained performance

Sustained performance requires continued investment.

Beazley continued to invest in the future development of the business in the first half of 2014, recruiting new underwriters to the property division in London, and expanding the scope of the marine division to include satellite insurance and the specialty lines division to include surety reinsurance.

Beazley plc is the parent company of our specialist insurance business with operations in Europe, the US, Latin America, Asia and Australia. Beazley is a proud participant in the Lloyd's market, one of the largest and oldest insurance markets in the world. Through the Lloyd's broker network and the market's trading licences, we are able to access a wide range of insurance and reinsurance business from around the world. Many of the lines of business we underwrite, such as marine and energy, political risks and contingency, were pioneered at Lloyd's.

Beazley manages five Lloyd's syndicates: syndicates 2623 and 623 underwrite a broad range of insurance and reinsurance business worldwide; syndicate 3623 focuses on personal accident and sport business along with providing reinsurance to Beazley Insurance Company, Inc. in the US; 3622 is a dedicated life syndicate; and 6107, the special purpose syndicate, writes reinsurance business.

We also underwrite business directly in the US admitted market through Beazley Insurance Company, Inc., an admitted carrier licensed to write in all 50 states.

In 2009 we incorporated an Irish reinsurer, Beazley Re Limited, which reinsures a proportion of the group's business.

Further information about us is available at:
www.beazley.com

Contents

- 1 Highlights and key performance indicators
- 3 Interim results statement
- 6 Beazley timeline
- 8 Performance by division
- 10 Condensed consolidated statement of profit or loss
- 11 Condensed consolidated statement of comprehensive income
- 11 Condensed consolidated statement of changes in equity
- 12 Condensed consolidated statement of financial position
- 13 Condensed consolidated statement of cash flows
- 14 Notes to the condensed consolidated interim financial statements
- 32 Responsibility statement of the directors in respect of the interim report
- 33 Independent review report to Beazley plc
- 34 Glossary
- 36 Company information

Highlights and key performance indicators

Strong performance in first half of 2014 with profit before tax rising by 61% over the equivalent period in 2013.

Highlights

	6 months 2014	6 months 2013	Full year 2013
Gross premiums written (\$m)	1,077.7	1,066.7	1,970.2
Net premiums written (\$m)*	889.2	758.0	1,676.5
Net earned premiums (\$m)	804.5	758.8	1,590.5
Profit before income tax (\$m)	132.9	82.3	313.3
Claims ratio	51%	52%	45%
Expense ratio	39%	37%	39%
Combined ratio	90%	89%	84%
Basic earnings per share (cents)	22.6	14.3	52.4
Net assets per share (cents)	249.7	231.1	266.5
Net tangible assets per share (cents)	231.5	209.8	248.3
Basic earnings per share (pence)	13.5	9.3	33.6
Net assets per share (pence)	146.0	152.0	160.6
Net tangible assets per share (pence)	135.4	138.0	149.6
Proposed dividend per share (pence)	3.1	2.9	24.9
Return on equity (annualised)	17%	12%	21%
Premium renewal rate change	(1%)	1%	1%
Annualised investment return	2.1%	—	1.0%

* Refer to note 1 for further details of a change to the estimation of written premiums ceded to reinsurers on proportional reinsurance contracts.

Highlights and key performance indicators *continued*

KPIs

Financial highlights

Earnings per share (c)

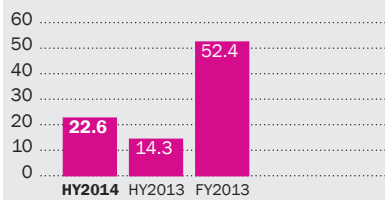

Net assets per share (c)

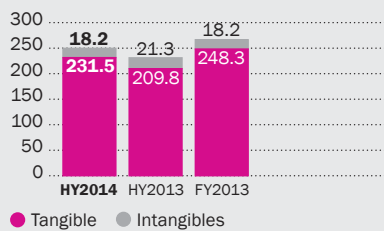

Gross premiums written (\$m)

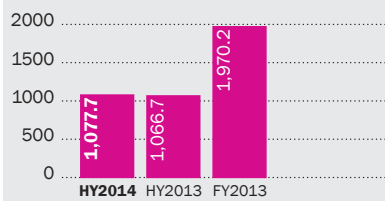

Dividends per share (p)

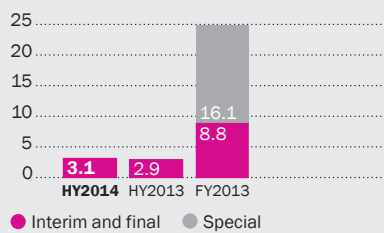

Return on equity (%)

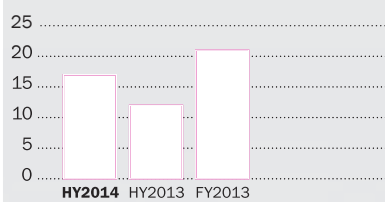

Combined ratio (%)

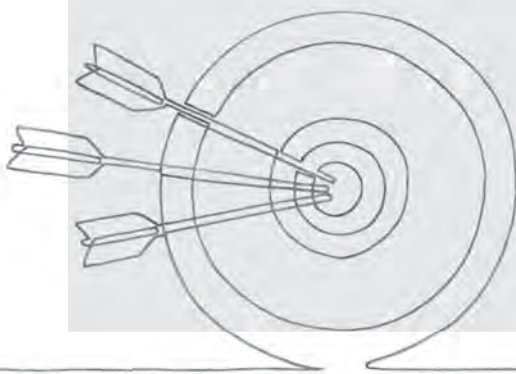
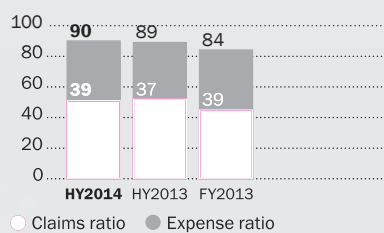

Interim results statement

In an increasingly competitive market, we are seeing more growth opportunities in smaller business lines, often underwritten locally in the US.



Andrew Horton
Chief executive

Beazley delivered a strong performance in the first half of 2014. Profit before tax rose 61% to \$132.9m (2013: \$82.3m), buoyed by enhanced investment returns and continuing strong underwriting profitability, helped by a lack of major catastrophe events.

In a market that is becoming much more competitive for many lines of business, gross written premiums rose by 1% from the equivalent period in 2013 to \$1,077.7m (2013: \$1,066.7m). We saw more opportunities in smaller business lines – often underwritten locally in the US – than in our large risks business underwritten mainly in London, where competition has often been intense.

Beazley now has 92 underwriters in the US, up from fewer than a dozen when we first began underwriting business locally in 2004. The rationale behind our expansion into the US market was to gain access to business that would not normally be seen by underwriters at Lloyd's. This has proven to be the case and this business grew 14% to \$238.2m in the first six months of 2014 (2013: \$208.1m). We expect our US platform to become increasingly important as we move forward.

Our largest division, specialty lines, has benefited from the steady recovery of the US economy, with demand for professional liability and management liability insurance increasing. This is not a precondition for the growth of our specialty lines business, but it certainly helps. Specialty lines business, which accounted for 36% of group premiums in the first half of the year, saw premium rates rise by an average of 1%.

Our second largest division, property, benefited from reduced reinsurance costs in the first half which meant that, although gross written premiums fell slightly, net premiums rose. Competition for the large risks business underwritten in London was intense, resulting in a contraction in this book. However, we continue to invest in the long term development of our open market property business, which focuses on large and complex property risks, announcing in July that two of the most respected underwriters of large risk property business at Lloyd's, Simon Jackson and John Brown, will be joining the team early in 2015.

Under Jonathan Gray's direction, open market property is one of many areas in which Beazley has carved a strong leadership position. Jonathan will be leaving Beazley next June after 23 years; as the founder and, for many years, the leader of our property division, his contribution to the company is inestimable. He will be succeeded as head of the open market property team by Simon Jackson.

We have seen the best market conditions in small and medium property risks and we are concentrating on these areas while the large risk property market remains more challenging.

Our marine division saw increased competition on hull and energy risks in particular, and rates for war risks – principally piracy risks off the horn of Africa – continued to fall. However, the marine division's business lines are more diversified than in previous years and our marine liability and aviation businesses continued to grow.

As highlighted in our 2013 annual report, there has been a large influx of new capital from pension funds into the reinsurance market, a process that has continued to depress rates this year. Our reinsurance division, representing 15% of our total gross premiums, has seen rates on renewals fall by 10%. With offices serving local reinsurance markets in Europe, Singapore and Latin America, we now have good access to non-US business.

Interim results statement *continued*

Cumulative renewal rate changes since 2001 (%)

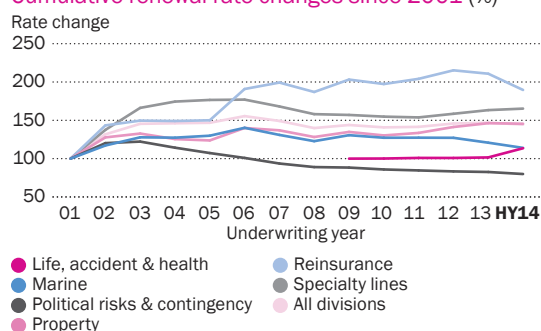

We continue to invest in underwriting talent and claims expertise, as well as in the skills and technology to bring new products to market and deliver excellent service to our clients and brokers. These investments include diversification into new lines of business that we see as promising. In January Denis Bensoussan joined us in London to establish a satellite insurance capability and in June Thomas Moore joined our New York office to underwrite surety reinsurance in the US and Canada. Both Denis and Tom are seasoned underwriters with track records of profitable underwriting based on prudent risk selection.

Wherever possible, we seek to promote internally as such opportunities arise. In May we appointed Suzanne White to head Beazley's accident and health business in Australia, reporting to Christian Tolle, head of Beazley's life, accident & health division. The combined ratio of the division was severely impacted by challenging market conditions in Australia in 2013. We took corrective action, with large rate rises, and the division's performance has improved in the first half of this year.

We continue to see strong demand for our fastest growing product – Beazley Breach Response – which protects companies against the impact of data breaches involving the loss or theft of personally identifiable customer data. BBR Services, the dedicated business unit that focuses on data breach response management, has helped clients manage approximately 1,500 data breaches successfully since the product was launched in 2009. In the vast majority of these cases, the clients' need has been exclusively for advice and support in the management of the data breach, rather than for indemnification against third party claims.

Investment performance

Our portfolio returned 1.1% in the half year, with the principal contribution coming from the core portfolio.

There have been no major changes to investment strategy during the period. We maintained our duration in the 1.5-2.0 year range and as corporate spreads tightened, we made reallocations across different credit sectors towards those that we believe present the best value.

Within the capital growth assets we are in the process of reallocating about 5% of the portfolio away from hedge funds targeting uncorrelated returns into funds targeting illiquid investments.

We are delighted to announce that Stuart Simpson will be joining Beazley as our senior investment officer. We have also completed the renegotiation of our contract with Falcon Money Management Limited who will continue in a reduced role focused on the capital growth portfolio.

The breakdown of our investment portfolio at 30 June 2014 was:

	30 June 2014 \$m	30 June 2014 %	30 June 2013 \$m	30 June 2013 %
Cash and cash equivalents	372.6	8.5	304.3	7.3
Fixed income: sovereign and supranational	1,933.4	44.2	2,313.4	55.1
Investment grade credit	1,473.7	33.6	1,002.0	23.9
Other credit	75.1	1.7	95.3	2.3
Core portfolio	3,854.8	88.0	3,715.0	88.6
Capital growth assets	526.8	12.0	480.3	11.4
Total	4,381.6	100.0	4,195.3	100.0

As at 30 June 2014, the weighted average duration of our fixed income portfolios (including cash, government bonds and credit investments) is 1.7 years (31 December 2013: 1.8 years) and the average rating of the investment grade credit is A.

Investment return by major asset class

Analysis of returns on major asset classes are set out below:

	30 June 2014 \$m	30 June 2014 annualised return %	30 June 2013 \$m	30 June 2013 annualised return %
Core portfolio	33.4	1.7	(7.9)	(0.4)
Capital growth assets	13.4	5.1	8.2	3.7
Overall return	46.8	2.1	0.3	-

Investment portfolio split

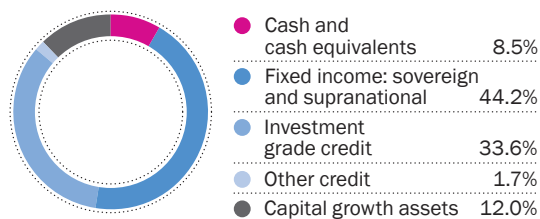

Capital position

Beazley maintains a robust capital position at the half year. In addition, the \$225m banking facility remains unused. The board will review the balance sheet capital position and consider whether any capital action is appropriate at the end of the year when the 2015 capital requirements and the 2014 full year result are certain.

We continue to manage our capital actively, as demonstrated through the payment of the special dividend announced in the 2013 results, whilst retaining the flexibility to capitalise on attractive investment opportunities.

The current solvency capital requirement to ultimate (uSCR), which is the capital our solvency II model estimates is required to support our syndicates' business plan, is broadly unchanged from year end 2013.

	2014 HY \$m	2013 FY \$m
Lloyd's capital requirement (uSCR)	977.1	979.1
Capital for US insurance company	107.7	107.7
Total	1,084.8	1,086.8

Dividend

The board has declared a first interim dividend of 3.1 pence (2013: 2.9 pence), in line with our strategy of delivering 5-10% dividend growth. This will be paid on 29 August 2014 to shareholders on the register at 5.00pm on 1 August 2014.

Outlook

We expect the trends that have emerged with increasing clarity in the first half of the year to carry through to the second half. Our view is that professional liability and management liability lines will be subject to less competition than short tail catastrophe-exposed lines of business. Smaller scale risks will offer more attractive opportunities than large scale risks and, in line with this, our US platform should continue to grow while our London market book may contract.

Underwriting profitability in all of our business lines will remain our overriding objective.

Andrew Horton

Chief executive

21 July 2014

28 years of profitable growth

Beazley's vision is to become, and be recognised as, the highest performing specialist insurer.

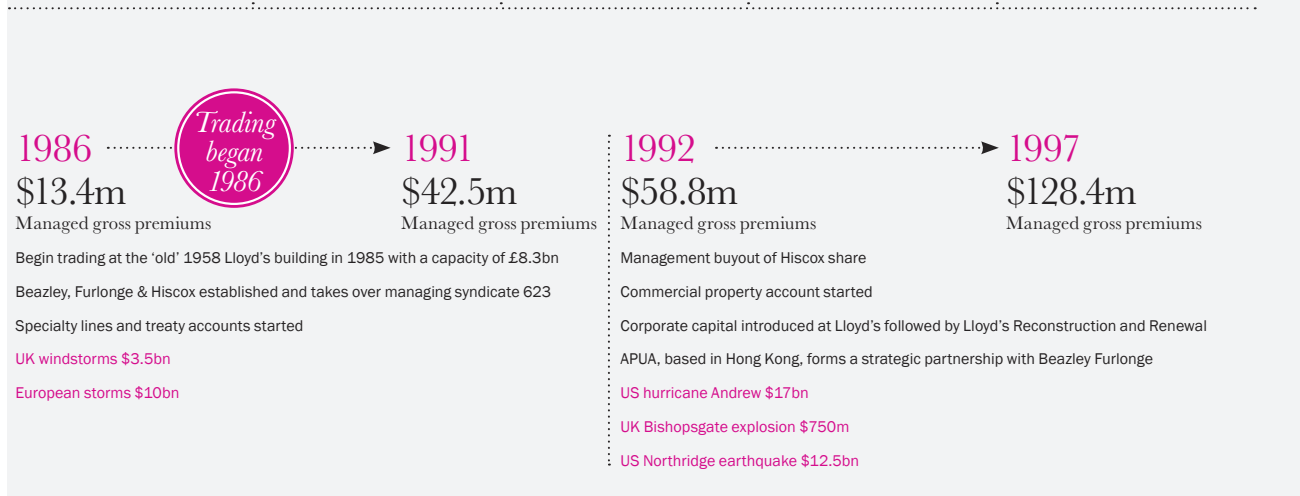

Beazley began life in 1986. Since then, we have grown steadily in terms of the risks we cover, the clients we serve and our geographic reach, and today Beazley is a mature insurance business with a well-diversified portfolio. We have weathered some of the toughest times the Lloyd's market has seen in more than three centuries and our underwriting operations have an unbroken record of profitability.

2009	2010	2011	2012	2013
\$2,121.7m Managed gross premiums	\$2,108.5m Managed gross premiums	\$2,079.2m Managed gross premiums	\$2,278.0m Managed gross premiums	\$2,352.3m Managed gross premiums
\$1,751.3m Group share	\$1,741.6m Group share	\$1,712.5m Group share	\$1,895.9m Group share	\$1,970.2m Group share
<p>Raised £150m through rights issue to develop our business at Lloyd's and in the US</p> <p>Acquisition of First State Management Group, Inc., a US underwriting manager focusing on surplus lines commercial property business</p> <p>Beazley plc becomes the new holding company for the group, incorporated in Jersey and tax-resident in Ireland</p>	<p>Andrew Beazley, co-founder of Beazley Group and chief executive until September 2008, dies at the age of 57</p> <p>Beazley changes functional and presentational currency to US dollar</p> <p>Beazley opens new office in Oslo</p> <p>Special purpose syndicate 6107 formed to grow reinsurance business</p> <p>Chile and NZ earthquakes \$13.5bn</p> <p>Deepwater Horizon explosion triggers biggest oil spill in history</p>	<p>Expansion of Australian accident and health business through acquisition of two MGAs</p> <p>Launch of the Andrew Beazley Broker Academy</p> <p>Nick Furlonge, co-founder, retires as an executive member but becomes a non-executive of Beazley Furlonge Limited</p> <p>Beazley remains profitable in worst year ever for insured natural catastrophe losses</p> <p>Tohoku earthquake in Japan \$35bn</p> <p>Floods in Thailand \$15bn</p> <p>US tornadoes \$14bn</p> <p>NZ earthquake \$15bn</p>	<p>Expansion into aviation and kidnap & ransom markets</p> <p>Reinsurance division broadens access to South East Asia, China and South Korea business with local presence in Singapore</p> <p>Political risk & contingency expand into French market</p> <p>Superstorm Sandy \$20-25bn</p>	<p>Construction Consortium launched at Lloyd's</p> <p>Miami office opened to access Latin American reinsurance business</p> <p>Beazley Flight - comprehensive emergency evacuation cover - launched</p> <p>Beazley data breach cover extended in Europe. 1,000th breach managed</p> <p>Local representation added in Rio to develop Latin American insurance business</p>

1998	2000	2001	2002	2003
\$168.8m Managed gross premiums	\$256.1m Managed gross premiums	\$431.6m Managed gross premiums	Flotation 2002	\$1,148.7m Managed gross premiums
<p>Recall, contingency and political risks accounts started</p> <p>Marine account started</p> <p>European storms \$12bn</p>		<p>Management buyout of minority shareholders</p> <p>EPL and UK PI accounts started</p> <p>Flotation raised £150m to set up Beazley Group plc</p> <p>D&O healthcare, energy, cargo and specie accounts started</p> <p>US 9/11 terrorist attack \$20.3bn</p> <p>SARS outbreak in Asia \$3.5bn</p>		

Performance by division

Our diversified and well-balanced portfolio generated a combined ratio of 90% in the first half of the year.

Life, accident & health



Christian Tolle
Head of life, accident & health

Combined ratio (%)

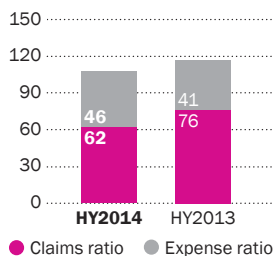

	HY 2014 \$m	HY 2013 \$m
Gross premiums written	81.5	56.4
Net premiums written*	62.9	39.0
Results from operating activities	(1.9)	(7.1)
Claims ratio	62%	76%
Expense ratio	46%	41%
Combined ratio	108%	117%
Rate change	12%	(1%)

Marine



Clive Washbourn
Head of marine

Combined ratio (%)

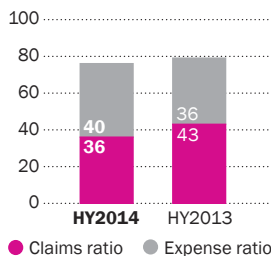

	HY 2014 \$m	HY 2013 \$m
Gross premiums written	196.7	197.1
Net premiums written*	163.1	165.2
Results from operating activities	41.3	27.2
Claims ratio	36%	43%
Expense ratio	40%	36%
Combined ratio	76%	79%
Rate change	(5%)	(2%)

Political risks & contingency



Adrian Lewers
Head of political risks & contingency

Combined ratio (%)

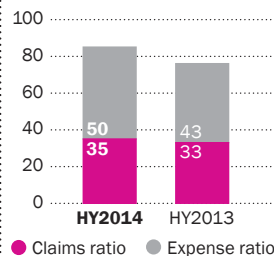

	HY 2014 \$m	HY 2013 \$m
Gross premiums written	60.4	63.3
Net premiums written*	47.7	46.0
Results from operating activities	9.4	11.6
Claims ratio	35%	33%
Expense ratio	50%	43%
Combined ratio	85%	76%
Rate change	(3%)	(1%)

* Refer to note 1 for further details of a change to the estimation of reinsurance premiums written on proportional reinsurance contracts.





Neil Maidment
Chief underwriting officer

Property



Mark Bernacki
Head of property

Combined ratio (%)

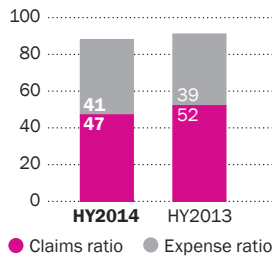

	HY 2014 \$m	HY 2013 \$m
Gross premiums written	190.7	199.0
Net premiums written*	151.8	130.1
Results from operating activities	26.7	16.3
Claims ratio	47%	52%
Expense ratio	41%	39%
Combined ratio	88%	91%
Rate change	-	3%

Reinsurance



Patrick Hartigan
Head of reinsurance

Combined ratio (%)

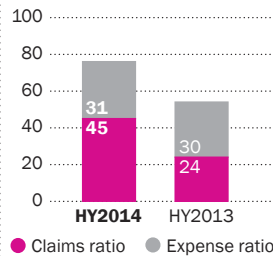

	HY 2014 \$m	HY 2013 \$m
Gross premiums written	163.1	170.3
Net premiums written*	124.8	121.1
Results from operating activities	26.6	32.2
Claims ratio	45%	24%
Expense ratio	31%	30%
Combined ratio	76%	54%
Rate change	(10%)	(1%)

Specialty lines



Adrian Cox
Head of specialty lines

Combined ratio (%)

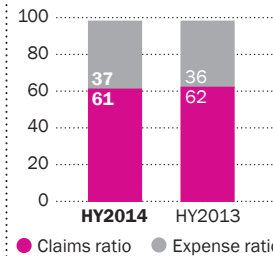

	HY 2014 \$m	HY 2013 \$m
Gross premiums written	385.3	380.6
Net premiums written*	338.9	256.6
Results from operating activities	39.0	8.1
Claims ratio	61%	62%
Expense ratio	37%	36%
Combined ratio	98%	98%
Rate change	1%	4%

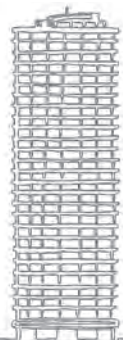

Condensed consolidated statement of profit or loss

for the six months ended 30 June 2014

	Note	Unaudited 6 months ended 30 June 2014 \$m	Unaudited 6 months ended 30 June 2013 \$m	Audited Year to 31 December 2013 \$m
Gross premiums written	2	1,077.7	1,066.7	1,970.2
Written premiums ceded to reinsurers*		(188.5)	(308.7)	(293.7)
Net premiums written	2	889.2	758.0	1,676.5
Change in gross provision for unearned premiums		(130.1)	(143.6)	(64.2)
Reinsurer's share of change in the provision for unearned premiums		45.4	144.4	(21.8)
Change in net provision for unearned premiums		(84.7)	0.8	(86.0)
Net earned premiums	2	804.5	758.8	1,590.5
Net investment income	3	46.8	0.3	43.3
Other income	4	10.6	14.4	36.4
		57.4	14.7	79.7
Revenue	2	861.9	773.5	1,670.2
Insurance claims		453.0	474.7	877.1
Insurance claims recovered from reinsurers		(41.8)	(78.6)	(158.0)
Net insurance claims	2,11	411.2	396.1	719.1
Expenses for the acquisition of insurance contracts		221.3	208.5	431.5
Administrative expenses		92.7	71.7	187.8
Foreign exchange (gain)/loss	2	(4.5)	8.8	3.0
Operating expenses		309.5	289.0	622.3
Expenses	2	720.7	685.1	1,341.4
Share of loss in associate	2	(0.1)	(0.1)	(0.3)
Results of operating activities		141.1	88.3	328.5
Finance costs	5	(8.2)	(6.0)	(15.2)
Profit before income tax		132.9	82.3	313.3
Income tax expense	8	(18.8)	(10.2)	(49.3)
Profit after income tax - all attributable to equity shareholders		114.1	72.1	264.0

* Refer to note 1 for further details of a change to the estimation of written premiums ceded to reinsurers on proportional reinsurance contracts.

Earnings per share (cents per share):

Basic	6	22.6	14.3	52.4
Diluted	6	21.9	14.0	51.2

Earnings per share (pence per share):

Basic	6	13.5	9.3	33.6
Diluted	6	13.1	9.1	32.8

Condensed consolidated statement of comprehensive income

for the six months ended 30 June 2014

	Unaudited 6 months to 30 June 2014 \$m	Unaudited 6 months to 30 June 2013 \$m	Audited Year to 31 December 2013 \$m
Profit after income tax	114.1	72.1	264.0
Other comprehensive income			
<i>Items that will never be reclassified to profit or loss:</i>			
Loss on remeasurement of retirement benefit obligations	-	-	(3.1)
<i>Items that may be reclassified subsequently to profit or loss:</i>			
Foreign currency translation differences	1.2	(1.8)	3.1
Total other comprehensive income	1.2	(1.8)	-
Total comprehensive income recognised	115.3	70.3	264.0

Condensed consolidated statement of changes in equity

for the six months ended 30 June 2014

	Share capital \$m	Share premium \$m	Foreign currency translation reserve \$m	Other reserves \$m	Retained earnings \$m	Total \$m
Balance as at 1 January 2013	41.6	12.0	(86.2)	(42.6)	1,279.7	1,204.5
Total comprehensive income recognised	-	-	(1.8)	-	72.1	70.3
Dividends paid	-	-	-	-	(107.3)	(107.3)
Equity settled share-based payments	-	-	-	7.5	-	7.5
Acquisition of own shares held in trust	-	-	-	(17.7)	-	(17.7)
Transfer of shares to employees	-	-	-	2.9	(2.6)	0.3
Balance as at 30 June 2013	41.6	12.0	(88.0)	(49.9)	1,241.9	1,157.6
Total comprehensive income recognised	-	-	4.9	-	188.8	193.7
Dividends paid	-	-	-	-	(22.6)	(22.6)
Equity settled share-based payments	-	-	-	11.6	(2.1)	9.5
Transfer of shares to employees	-	-	-	0.5	-	0.5
Balance as at 31 December 2013	41.6	12.0	(83.1)	(37.8)	1,406.0	1,338.7
Total comprehensive income recognised	-	-	1.2	-	114.1	115.3
Dividends paid	-	-	-	-	(186.6)	(186.6)
Equity settled share-based payments	-	-	-	4.3	-	4.3
Acquisition of own shares held in trust	-	-	-	(9.7)	-	(9.7)
Transfer of shares to employees	-	-	-	1.9	(1.9)	-
Balance as at 30 June 2014	41.6	12.0	(81.9)	(41.3)	1,331.6	1,262.0

Condensed consolidated statement of financial position

as at 30 June 2014

	Note	Unaudited 30 June 2014 \$m	Unaudited 30 June 2013 \$m	Audited 31 December 2013 \$m
Assets				
Intangible assets		92.1	106.7	91.6
Plant and equipment		4.9	5.5	6.0
Investments in associates		9.9	9.9	8.4
Deferred acquisition costs		226.4	214.8	206.0
Deferred tax asset		8.3	10.4	8.7
Reinsurance assets		1,205.8	1,335.6	1,178.2
Financial assets at fair value*	9	4,009.0	3,891.0	4,043.6
Insurance receivables		686.5	635.7	617.7
Retirement benefit asset		-	0.9	-
Other receivables		33.8	26.9	41.7
Cash and cash equivalents*	10	372.6	304.3	382.7
Total assets		6,649.3	6,541.7	6,584.6
Equity				
Share capital		41.6	41.6	41.6
Share premium		12.0	12.0	12.0
Foreign currency translation reserve		(81.9)	(88.0)	(83.1)
Other reserves		(41.3)	(49.9)	(37.8)
Retained earnings		1,331.6	1,241.9	1,406.0
Total equity		1,262.0	1,157.6	1,338.7
Liabilities				
Insurance liabilities		4,776.0	4,639.4	4,577.3
Financial liabilities	9	279.8	252.3	274.9
Retirement benefit liability		0.7	-	2.4
Deferred tax liabilities		2.3	59.1	65.0
Current income tax liabilities		70.6	14.2	18.5
Other payables		257.9	419.1	307.8
Total liabilities		5,387.3	5,384.1	5,245.9
Total equity and liabilities		6,649.3	6,541.7	6,584.6

* Deposits to the value of \$296.6m (30 June 2013: \$313.6m, 31 December 2013: \$307.3m) managed centrally by Lloyd's are now included in financial assets and no longer classified as cash and cash equivalents. The reclassification was reflected in the previously issued 2013 audited financial statements.

D A Horton
Chief executive

M L Bride
Finance director

21 July 2014

Condensed consolidated statement of cash flows

for the six months ended 30 June 2014

	Unaudited 6 months ended 30 June 2014 \$m	Unaudited 6 months ended 30 June 2013 \$m	Audited Year to 31 December 2013 \$m
Cash flow from operating activities			
Profit before income tax	132.9	82.3	313.3
Adjustments for:			
Amortisation of intangibles	2.2	7.9	14.2
Equity settled share based compensation	4.3	7.5	19.1
Net fair value (gain)/loss on financial investments	(20.1)	28.7	15.0
Share of loss on associate	0.1	0.1	0.3
Depreciation of plant and equipment	1.2	1.3	2.4
Impairment of reinsurance assets recognised/(written back)	1.1	(0.2)	(3.5)
Impairment loss recognised on intangible assets	-	-	11.5
Impairment loss recognised on investment in associates	-	-	1.4
Increase in insurance and other liabilities	151.1	193.5	37.1
Increase in insurance, reinsurance and other receivables	(89.6)	(200.3)	(36.4)
Increase in deferred acquisition costs	(20.4)	(29.8)	(21.0)
Interest and dividend income	(32.2)	(34.5)	(68.7)
Finance expense	8.2	8.1	17.3
Profit on debt buy back	-	(2.1)	(2.1)
Income tax paid	(29.0)	(19.1)	(46.4)
Net cash from operating activities	109.8	43.4	253.5
Cash flow from investing activities			
Purchase of plant and equipment	(0.1)	(0.1)	(1.5)
Expenditure on software development	(2.3)	(3.0)	(5.1)
Purchase of investments*	(1,494.2)	(2,243.7)	(3,079.5)
Proceeds from sale of investments	1,548.9	2,329.3	3,026.3
Investment in associate	(1.6)	-	(0.1)
Interest and dividends received	32.2	34.5	68.7
Net cash from investing activities	82.9	117.0	8.8
Cash flow from financing activities			
Acquisition of own shares in trust	(9.7)	(17.7)	(17.7)
Repayment of borrowings	-	(39.5)	(39.5)
Interest paid	(7.2)	(8.1)	(13.5)
Dividends paid	(186.6)	(107.3)	(129.9)
Net cash used in financing activities	(203.5)	(172.6)	(200.6)
Net (decrease)/increase in cash and cash equivalents	(10.8)	(12.2)	61.7
Cash and cash equivalents at beginning of period*	382.7	316.5	316.5
Effect of exchange rate changes on cash and cash equivalents	0.7	-	4.5
Cash and cash equivalents at end of period*	372.6	304.3	382.7

* Deposits to the value of \$296.6m (30 June 2013: \$313.6m, 31 December 2013: \$307.3m) managed centrally by Lloyd's are now included in financial assets and no longer classified as cash and cash equivalents. The reclassification was reflected in the previously issued 2013 audited financial statements.

Notes to the condensed consolidated interim financial statements

for the six months ended 30 June 2014

1 Statement of accounting policies

Beazley plc is a group incorporated in Jersey and domiciled in Ireland. The condensed consolidated interim financial statements of the group for the six months ended 30 June 2014 comprise the parent company and its subsidiaries and the group's interest in associates.

The condensed consolidated interim financial statements have been prepared and approved by the directors in accordance with IAS 34 Interim Financial Reporting as adopted by the EU ('Adopted IFRS').

The preparation of condensed consolidated interim financial statements requires management to make judgements, estimates and assumptions that affect the application of accounting policies and the reported amounts of assets and liabilities, income and expenses. Actual results may differ from these estimates. The significant judgements made by management in applying the group's accounting policies and the key sources of estimation uncertainty were the same as those that applied to the consolidated financial statements as at, and for, the year ended 31 December 2013. As required by IFRS 13 (fair value measurement) information relating to the fair value measurement of financial assets and liabilities is outlined in note 9 to the condensed consolidated interim financial statements.

In the current year, the group changed the estimation basis used for written premiums ceded to reinsurers relating to proportional reinsurance contracts. The impact of this change is to recognise written premiums ceded to reinsurers on proportional reinsurance contracts more evenly over the course of the financial year, with no impact to ceded reinsurance earned premiums or net earned premiums. We estimate that this change will result in an additional \$120m of written premiums ceded to reinsurers on proportional reinsurance contracts, which would previously have been recognised in the first half of the year, being recognised in the second half of 2014. This change has been applied on a prospective basis in the condensed consolidated interim financial statements, and will not have any impact on net earned premiums, profit or net assets in the group's annual report for the year ended 31 December 2014.

Except as described below, the accounting policies applied in these condensed consolidated interim financial statements are the same as those applied in the group's consolidated financial statements as at, and for, the year ended 31 December 2013. Any changes in accounting policies are also expected to be reflected in the group's consolidated financial statements as at, and for, the year ending 31 December 2014.

As a result of IFRS 10 (consolidated financial statements), with a date of initial application of 1 January 2014, the group has changed its accounting policy for determining whether it has control over and consequently whether it consolidates its investees. IFRS 10 introduces a new control model that focuses on whether the group has power over an investee, exposure or rights to variable returns from its involvement with the investee and ability to use its power to affect those returns.

In accordance with the transitional provisions of IFRS 10, the group reassessed the control conclusion, including a review of relationships influencing the group's associates, subsidiaries and other related parties, for its investees at 1 January 2014. The group has not changed any of its control conclusions in respect of any investments in subsidiaries or associates. For the syndicates that it manages, the group has concluded that it remains appropriate to consolidate its proportionate economic interest in these syndicates.

In addition to IFRS 10 discussed above, our annual report for the year ended 31 December 2013 noted that the following list of standards were effective from 1 January 2014 in the EU;

- IFRS 11: Joint arrangements;
- IFRS 12: Disclosure of interests in other entities;
- IAS 19: Amendment: Defined benefit plans: Employee Contributions;
- IAS 27: Amendment: Separate financial statements;
- IAS 28: Amendment: Investments in associates and joint ventures;
- IAS 32: Amendment: Offsetting financial assets and financial liabilities;
- IAS 36: Amendment: Recoverable amount disclosures for non-financial assets;
- IAS 39: Amendment: Novation of derivatives and continuation of hedge accounting; and
- IFRIC 21: Levies.

The adoption of these standards has had no material impact on the group's accounting policies.

The financial information included in this document does not comprise statutory financial statements within the meaning of Companies (Jersey) Law 1991. The comparative figures for the financial year ended 31 December 2013 are those for the group and are not the company's statutory financial statements for that financial year. Those financial statements have been reported on by the company's auditors and delivered to the Jersey Financial Services Commission. The report of the auditors was unqualified.

2 Segmental analysis

Segment information is presented in respect of reportable segments. This is based on the group's management and internal reporting structures and represents the level at which financial information is reported to the board, being the chief operating decision maker as defined in IFRS 8.

Finance costs and taxation have not been allocated to operating segments as these items are determined by group level factors and do not relate to operating performance.

	30 June 2014						
	Life, accident & health \$m	Marine \$m	Political risks & contingency \$m	Property \$m	Reinsurance \$m	Specialty lines \$m	Total \$m
Gross premiums written	81.5	196.7	60.4	190.7	163.1	385.3	1,077.7
Net premiums written*	62.9	163.1	47.7	151.8	124.8	338.9	889.2
Net earned premiums	42.9	143.9	42.8	145.9	80.1	348.9	804.5
Net investment income	0.8	5.1	2.2	5.8	4.7	28.2	46.8
Other income	-	1.3	0.5	2.5	1.5	4.8	10.6
Revenue	43.7	150.3	45.5	154.2	86.3	381.9	861.9
Net insurance claims	26.5	52.2	15.0	68.8	36.2	212.5	411.2
Expenses for the acquisition of insurance contracts	13.6	42.1	13.4	42.9	17.7	91.6	221.3
Administrative expenses	6.1	15.3	8.1	16.8	6.9	39.5	92.7
Foreign exchange gain	(0.6)	(0.6)	(0.3)	(1.0)	(1.1)	(0.9)	(4.5)
Expenses	45.6	109.0	36.2	127.5	59.7	342.7	720.7
Share of profit/(loss) in associate	-	-	0.1	-	-	(0.2)	(0.1)
Segment result	(1.9)	41.3	9.4	26.7	26.6	39.0	141.1
Finance costs							(8.2)
Profit before income tax							132.9
Income tax expense							(18.8)
Profit after income tax							114.1
Claims ratio	62%	36%	35%	47%	45%	61%	51%
Expense ratio	46%	40%	50%	41%	31%	37%	39%
Combined ratio	108%	76%	85%	88%	76%	98%	90%

Segment assets and liabilities

Segment assets	224.3	1,110.2	795.4	1,025.1	384.5	3,109.8	6,649.3
Segment liabilities	(195.5)	(740.5)	(639.8)	(862.1)	(270.1)	(2,679.3)	(5,387.3)
Net assets	28.8	369.7	155.6	163.0	114.4	430.5	1,262.0

* Refer to note 1 for further details of a change to the estimation of written premiums ceded to reinsurers on proportional reinsurance contracts.

Notes to the condensed consolidated interim financial statements *continued*

for the six months ended 30 June 2014

2 Segmental analysis *continued*

	30 June 2013						
	Life, accident & health \$m	Marine \$m	Political risks & contingency \$m	Property \$m	Reinsurance \$m	Specialty lines \$m	Total \$m
Gross premiums written	56.4	197.1	63.3	199.0	170.3	380.6	1,066.7
Net premiums written	39.0	165.2	46.0	130.1	121.1	256.6	758.0
Net earned premiums	45.4	131.5	46.3	150.2	70.8	314.6	758.8
Net investment income	-	-	-	-	-	0.3	0.3
Other income	1.0	1.5	0.9	4.9	0.6	5.5	14.4
Revenue	46.4	133.0	47.2	155.1	71.4	320.4	773.5
Net insurance claims	34.2	57.2	15.6	77.8	17.3	194.0	396.1
Expenses for the acquisition of insurance contracts	12.9	35.1	11.9	48.8	13.9	85.9	208.5
Administrative expenses	5.9	11.9	7.8	10.5	7.0	28.6	71.7
Foreign exchange loss	0.5	1.6	0.5	1.7	1.0	3.5	8.8
Expenses	53.5	105.8	35.8	138.8	39.2	312.0	685.1
Share of profit/(loss) in associate	-	-	0.2	-	-	(0.3)	(0.1)
Segment result	(7.1)	27.2	11.6	16.3	32.2	8.1	88.3
Finance costs							(6.0)
Profit before income tax							82.3
Income tax expense							(10.2)
Profit after income tax							72.1
Claims ratio	76%	43%	33%	52%	24%	62%	52%
Expense ratio	41%	36%	43%	39%	30%	36%	37%
Combined ratio	117%	79%	76%	91%	54%	98%	89%
Segment assets and liabilities							
Segment assets	224.6	1,072.6	778.6	1,013.3	382.2	3,070.4	6,541.7
Segment liabilities	(181.0)	(725.9)	(627.4)	(890.0)	(306.1)	(2,653.7)	(5,384.1)
Net assets	43.6	346.7	151.2	123.3	76.1	416.7	1,157.6

2 Segmental analysis *continued*

	31 December 2013						
	Life, accident & health \$m	Marine \$m	Political risks & contingency \$m	Property \$m	Reinsurance \$m	Specialty lines \$m	Total \$m
Gross premiums written	100.3	315.9	131.2	371.4	221.6	829.8	1,970.2
Net premiums written	96.1	282.1	110.1	308.7	171.5	708.0	1,676.5
Net earned premiums	95.4	264.4	98.6	302.6	165.3	664.2	1,590.5
Net investment income	0.5	4.6	2.2	5.9	4.7	25.4	43.3
Other income	5.8	4.1	2.6	10.5	2.2	11.2	36.4
Revenue	101.7	273.1	103.4	319.0	172.2	700.8	1,670.2
Net insurance claims	70.8	88.7	4.7	122.2	29.5	403.2	719.1
Expenses for the acquisition of insurance contracts	27.7	71.3	26.8	99.5	34.1	172.1	431.5
Administrative expenses	21.0	29.6	17.4	31.5	17.5	70.8	187.8
Foreign exchange loss	0.1	0.5	0.2	0.6	0.4	1.2	3.0
Expenses	119.6	190.1	49.1	253.8	81.5	647.3	1,341.4
Share of profit/(loss) in associate	-	-	0.1	-	-	(0.4)	(0.3)
Segment result	(17.9)	83.0	54.4	65.2	90.7	53.1	328.5
Finance costs							(15.2)
Profit before income tax							313.3
Income tax expense							(49.3)
Profit after income tax							264.0
Claims ratio	74%	34%	5%	40%	18%	61%	45%
Expense ratio	51%	38%	45%	44%	31%	36%	39%
Combined ratio	125%	72%	50%	84%	49%	97%	84%
Segment assets and liabilities							
Segment assets	221.4	1,089.8	785.7	1,016.9	384.2	3,086.6	6,584.6
Segment liabilities	(187.1)	(701.2)	(614.9)	(852.6)	(269.8)	(2,620.3)	(5,245.9)
Net assets	34.3	388.6	170.8	164.3	114.4	466.3	1,338.7

Notes to the condensed consolidated interim financial statements *continued*

for the six months ended 30 June 2014

3 Net investment income

	6 months ended 30 June 2014 \$m	6 months ended 30 June 2013 \$m	Year to 31 December 2013 \$m
Interest and dividends on financial investments at fair value through profit or loss	32.0	34.2	68.0
Interest on cash and cash equivalents	0.2	0.3	0.7
Realised losses on financial investments at fair value through profit or loss	(11.5)	(2.6)	(7.1)
Net unrealised fair value gain/(loss) on financial investments at fair value through profit or loss	31.6	(26.1)	(7.9)
Investment income from financial investments	52.3	5.8	53.7
Fair value gain on derivative financial instruments	-	-	-
Investment income	52.3	5.8	53.7
Investment management expenses	(5.5)	(5.5)	(10.4)
	46.8	0.3	43.3

Deposits managed centrally by Lloyd's are now included in financial assets and no longer classified as cash and cash equivalents. In accordance with this reclassification, we have reclassified investment income from interest to realised and unrealised fair value gains/(losses). The reclassification was reflected in the previously issued 2013 audited financial statements.

4 Other income

	6 months ended 30 June 2014 \$m	6 months ended 30 June 2013 \$m	Year to 31 December 2013 \$m
Commission income	6.5	9.9	23.2
Profit commissions	3.0	3.5	11.0
Agency fees	1.1	1.0	2.0
Other income	-	-	0.2
	10.6	14.4	36.4

5 Finance costs

	6 months ended 30 June 2014 \$m	6 months ended 30 June 2013 \$m	Year to 31 December 2013 \$m
Interest expense	8.2	8.1	16.2
Profit on debt buy back	-	(2.1)	(2.1)
Other finance costs	-	-	1.1
	8.2	6.0	15.2

During 2013 Beazley bought back a total nominal amount of \$39.5m of debt at a market value of \$37.4m in the form of fixed/floating rate subordinated notes falling due in 2026. A profit of \$2.1m was realised on the difference between the carrying value and the nominal amount of the debt bought back during the period.

6 Earnings per share

	6 months ended 30 June 2014	6 months ended 30 June 2013	Year to 31 December 2013
Basic (cents)	22.6	14.3	52.4
Diluted (cents)	21.9	14.0	51.2
Basic (pence)	13.5	9.3	33.6
Diluted (pence)	13.1	9.1	32.8

Basic

Basic earnings per share are calculated by dividing profit after income tax of \$114.1m (30 June 2013: \$72.1m; 31 December 2013: \$264.0m) by the weighted average number of shares in issue during the six months of 505.5m (30 June 2013: 503.1m; 31 December 2013: 503.7m). The shares held in the Employee Share Options Plan (ESOP) of 15.8m (30 June 2013: 17.8m; 31 December 2013: 17.3m) have been excluded from the calculation until such time as they vest unconditionally with the employees.

Diluted

Diluted earnings per share are calculated by dividing profit after income tax of \$114.1m (30 June 2013: \$72.1m; 31 December 2013: \$264.0m) by the adjusted weighted average number of shares of 521.9m (30 June 2013: 515.6m; 31 December 2013: 515.4m). The adjusted weighted average number of shares assumes conversion of dilutive potential ordinary shares, being shares from the SAYE (Save As You Earn), retention and deferred share schemes. The shares held in the ESOP of 15.8m (30 June 2013: 17.8m; 31 December 2013: 17.3m) have been excluded from the calculation until such time as they vest unconditionally with the employees.

7 Dividends

A first interim dividend of 3.1p per ordinary share (2013: 2.9p) is payable in respect of the six months to 30 June 2014. These financial statements do not provide for this dividend as a liability.

A second interim dividend of 5.9p per ordinary share and a special dividend of 16.1p was paid on 28 March 2014 to shareholders registered at 5.00pm on 28 February 2014 in respect of the six months ended 31 December 2013.

The first interim dividend will be payable on 29 August 2014 to shareholders registered at 5.00pm on 1 August 2014 (save to the extent that shareholders on the register of members on 1 August 2014 are to be paid a dividend by a subsidiary of the company (being Beazley DAS Limited) resident for tax purposes in the United Kingdom pursuant to elections made in which case such shareholders shall have a right to be paid the aforementioned dividend but shall have no right to the first interim dividend).

Notes to the condensed consolidated interim financial statements *continued*

for the six months ended 30 June 2014

8 Income tax expense

	6 months ended 30 June 2014 \$m	6 months ended 30 June 2013 \$m	Year to 31 December 2013 \$m
Current tax expense			
Current year	82.5	32.8	60.6
Prior year adjustments	(1.5)	1.6	4.3
	81.0	34.4	64.9
Deferred tax expense			
Origination and reversal of temporary differences	(61.0)	(20.7)	(12.1)
Impact of change in UK tax rates	0.1	-	(3.5)
Prior year adjustments	(1.3)	(3.5)	-
	(62.2)	(24.2)	(15.6)
Income tax expense	18.8	10.2	49.3
Profit before tax	132.9	82.3	313.3
Tax calculated at Irish tax rate (12.5%)	16.6	10.3	39.2
Effects of:			
- Tax rates in foreign jurisdictions	4.2	1.9	10.5
- Non-deductible expenses	0.7	0.3	1.7
- Tax relief on share based payments – current and future years	-	-	(0.3)
- Over provided in prior years	(2.8)	(1.9)	0.8
- Change in UK tax rates*	0.1	-	(3.8)
- Foreign exchange on tax	-	(0.4)	2.9
- Restriction of foreign tax recoverable	-	-	(1.7)
Tax charge for the period	18.8	10.2	49.3

* The Budget 2013 announced that the UK corporation rate would reduce to 21% at 1 April 2014, with a further reduction to 20% in 2015. The reductions in the UK tax rate to 21% (effective from 1 April 2014) and 20% (effective from 1 April 2015) were substantively enacted on 2 July 2013. These reductions will reduce the company's future current tax charge and the deferred tax liability at 30 June 2014 has thus been calculated based on the tax rates substantively enacted at the statement of financial position.

9 Financial assets and liabilities

	30 June 2014 \$m	30 June 2013 \$m	31 December 2013 \$m
Financial assets at fair value			
Hedge funds	443.0	408.4	435.8
Regulated equity linked funds	83.8	71.8	80.5
Fixed rate debt securities	2,518.0	2,881.4	2,629.9
Floating rate debt securities	959.9	526.6	893.0
Total financial investments at fair value through statement of profit or loss	4,004.7	3,888.2	4,039.2
Derivative financial instruments	4.3	2.8	4.4
Total financial assets at fair value	4,009.0	3,891.0	4,043.6
The amount expected to mature before and after one year are:			
Within one year	1,553.7	1,463.1	1,446.3
After one year	2,455.3	2,427.9	2,597.3
	4,009.0	3,891.0	4,043.6
Financial liabilities			
Retail bond	126.7	112.5	123.0
Subordinated debt	18.0	18.0	18.0
Tier 2 subordinated debt	135.1	121.8	132.1
Derivative financial instruments	-	-	1.8
Total financial liabilities	279.8	252.3	274.9
The amount expected to mature before and after one year are:			
Within one year	-	-	1.8
After one year	279.8	252.3	273.1
	279.8	252.3	274.9

Financial assets now include deposits managed centrally by Lloyd's which were previously classified as cash and cash equivalents. This classification also applies to comparative information provided. The reclassification was reflected in the previously issued 2013 audited financial statements.

Notes to the condensed consolidated interim financial statements *continued*

for the six months ended 30 June 2014

9 Financial assets and liabilities *continued*

Fair value measurement

The table on the next page summarises financial assets carried at fair value using a valuation hierarchy that reflects the significance of the inputs used in making the measurements. The fair value hierarchy has the following levels:

Level 1 – Valuations based on quoted prices in active markets for identical instruments. An active market is a market in which transactions for the instrument occur with sufficient frequency and volume on an ongoing basis such that quoted prices reflect prices at which an orderly transaction would take place between market participants at the measurement date. Included within level 1 are bonds and treasury bills of government and government agencies which are measured based on quoted prices.

Level 2 – Valuations based on quoted prices in markets that are not active, or based on pricing models for which significant inputs can be corroborated by observable market data (e.g. interest rates, exchange rates). Included within level 2 are government bonds and treasury bills which are not actively traded, corporate bonds, asset backed securities and mortgage-backed securities.

Level 3 – Valuations based on inputs that are unobservable or for which there is limited market activity against which to measure fair value.

The availability of financial data can vary for different financial assets and is affected by a wide variety of factors, including the type of financial instrument, whether it is new and not yet established in the marketplace, and other characteristics specific to each transaction. To the extent that valuation is based on models or inputs that are unobservable in the market, the determination of fair value requires more judgement. Accordingly the degree of judgement exercised by management in determining fair value is greatest for instruments classified in level 3. The group uses prices and inputs that are current as of the measurement date for valuation of these instruments.

If the inputs used to measure the fair value of an asset or a liability could be categorised in different levels of the fair value hierarchy, then the fair value measurement is categorised in its entirety in the same level of the fair value hierarchy as the lowest level input that is significant to the entire measurement.

The group has an established control framework and valuation policy with respect to the measurement of fair values. For the group's level 2 debt securities our fund administrator obtains the prices used in the valuation from independent pricing vendors such as Bloomberg, Standard & Poor's, Reuters, Markit and International Data Corporation. The independent pricing vendors derive an evaluated price from observable market inputs. The market inputs include trade data, two-sided markets, institutional bids, comparable trades, dealer quotes, news media, and other relevant market data. These inputs are verified in their pricing engines and calibrated with the pricing models to calculate spread to benchmarks, as well as other pricing assumptions such as Weighted Average life (WM), Discount Margins (DM), Default rates, and recovery and prepayments assumptions for mortgage securities. While such valuations are sensitive to estimates, it is believed that changing one or more of the assumptions to reasonably possible alternative assumptions would not change the fair value significantly.

The group records the unadjusted price provided and validates the price through various tolerance checks such as comparison with the investment custodians and the investment managers to assess the reasonableness and accuracy of the price to be used to value the security. In the rare case that the price fails the tolerance test, it is escalated and discussed internally. We would not normally override the price on a retrospective basis, but we would work with the administrator and pricing vendor to investigate the difference. We also review the valuation policy on a regular basis to ensure it is fit for purpose. No adjustments have been made to the prices obtained from the independent administrator.

For our hedge funds and regulated equity linked funds, the pricing and valuation of each fund is undertaken by independent administrators in accordance with each underlying funds valuation policy. For the regulated equity linked funds, the individual fund prices are published on a daily or weekly basis via Bloomberg and other market data providers such as Reuters. For the hedge funds, the individual fund prices are communicated by the independent administrators to all investors via the monthly investor statements. The fair value of the hedge fund and regulated equity linked fund portfolios are calculated by reference to the underlying net asset values of each of the individual funds.

Additional information is obtained from fund managers relating to the underlying assets within individual hedge funds and regulated equity linked funds. We identified that 69.2% (30 June 2013: 66.5%, 31 December 2013: 69.3%) of these underlying assets were level 1 and the remainder level 2. This enables us to categorise hedge funds as level 2.

9 Financial assets and liabilities *continued*

Fair value measurement *continued*

Prior to any new hedge fund investment, extensive due diligence is undertaken on each fund to ensure that pricing and valuation is undertaken by the independent administrators and that each fund's valuation policy is appropriate for the financial instruments the manager will be employing to execute the investment strategy.

The following table shows the fair values of financial assets and financial liabilities, including their levels in the fair value hierarchy.

	Level 1 \$m	Level 2 \$m	Level 3 \$m	Total \$m
30 June 2014				
Financial assets measured at fair value				
Fixed rate debt securities	1,386.6	1,131.4	-	2,518.0
Floating rate debt securities	265.5	694.4	-	959.9
Hedge funds	-	443.0	-	443.0
Regulated equity linked funds	-	83.8	-	83.8
Derivative financial instruments	4.3	-	-	4.3
Total financial assets measured at fair value	1,656.4	2,352.6	-	4,009.0
Financial liabilities measured at fair value				
Derivative financial instruments	-	-	-	-
Financial liabilities not measured at fair value				
Retail bond	-	132.7	-	132.7
Subordinated debt	-	18.0	-	18.0
Tier 2 subordinated debt	-	139.4	-	139.4
Total financial liabilities not measured at fair value	-	290.1	-	290.1
30 June 2013				
Financial assets measured at fair value				
Fixed rate debt securities	1,583.9	1,297.5	-	2,881.4
Floating rate debt securities	295.6	231.0	-	526.6
Hedge funds	-	408.4	-	408.4
Regulated equity linked funds	-	71.8	-	71.8
Derivative financial instruments	2.8	-	-	2.8
Total financial assets measured at fair value	1,882.3	2,008.7	-	3,891.0
Financial liabilities measured at fair value				
Derivative financial instruments	-	-	-	-
Financial liabilities not measured at fair value				
Retail bond	-	116.8	-	116.8
Subordinated debt	-	18.0	-	18.0
Tier 2 subordinated debt	-	121.8	-	121.8
Total financial liabilities not measured at fair value	-	256.6	-	256.6

Notes to the condensed consolidated interim financial statements *continued*

for the six months ended 30 June 2014

9 Financial assets and liabilities *continued*

31 December 2013	Level 1 \$m	Level 2 \$m	Level 3 \$m	Total \$m
Financial assets measured at fair value				
Fixed rate debt securities	1,435.0	1,194.9	-	2,629.9
Floating rate debt securities	250.6	642.4	-	893.0
Hedge funds	-	435.8	-	435.8
Regulated equity linked funds	-	80.5	-	80.5
Derivative financial instruments	4.4	-	-	4.4
Total financial assets measured at fair value	1,690.0	2,353.6	-	4,043.6
Financial liabilities measured at fair value				
Derivative financial instruments	1.8	-	-	1.8
Financial liabilities not measured at fair value				
Retail bond	-	128.9	-	128.9
Subordinated debt	-	18.0	-	18.0
Tier 2 subordinated debt	-	135.9	-	135.9
Total financial liabilities not measured at fair value	-	282.8	-	282.8

The table above does not include financial assets and financial liabilities if the carrying amount of these financial assets and liabilities approximates fair value at the reporting date.

Financial liabilities not measured at fair value are subsequently stated at amortised cost using the effective interest method. The fair value of the tier 2 subordinated debt and retail bond is based on quoted market prices. For the subordinated debt that is not quoted, a discounted cash flow model is used based on a current yield curve appropriate for the remaining term to maturity.

There were no transfers in either direction between level 1, 2 or 3 in 2014 and 2013.

10 Cash and cash equivalents

	30 June 2014 \$m	30 June 2013 \$m	31 December 2013 \$m
Cash at bank and in hand	300.3	210.8	266.6
Short-term deposits and highly liquid investments	72.3	93.5	116.1
	372.6	304.3	382.7

Deposits to the value of \$296.6m (30 June 2013: \$313.6m, 31 December 2013: \$307.3m) managed centrally by Lloyd's are now included in financial assets and no longer classified as cash and cash equivalents. This classification also applies to comparative information provided. The reclassification was reflected in the previously issued 2013 audited financial statements.

11 Insurance claims

The loss development tables below provide information about historical claims development by the six segments – life, accident and health, marine, political risks and contingency, property, reinsurance and specialty lines. The tables are by underwriting year which in our view provides the most transparent reserving basis. We have supplied tables for both ultimate gross claims ratio and ultimate net claims ratio.

The top part of the table illustrates how the group's estimated claims ratio for each underwriting year has changed at successive year-ends. The bottom half of the table reconciles the gross and net claims to the amount included in the statement of financial position.

While the information in the tables provide a historical perspective on the adequacy of the claims liabilities established in previous years, users of these financial statements are cautioned against extrapolating past redundancies or deficiencies on current claims liabilities. The group believes that the estimates of total claims liabilities as at 30 June 2014 are adequate. However, due to inherent uncertainties in the reserving process, it cannot be assured that such balances will ultimately prove to be adequate.

11 Insurance claims *continued*

Gross ultimate claims	2004 ae %	2005 %	2006 %	2007 %	2008 %	2009 %	2010 %	2011 %	2012 %	2013 %	2014 %	Total
Life, accident & health												
12 months		-	-	-	-	53.1	53.0	56.0	56.6	63.3		
24 months		-	-	-	-	52.1	52.6	52.1	68.1			
36 months		-	-	-	-	45.0	49.1	59.7				
48 months		-	-	-	-	43.3	48.3					
60 months		-	-	-	-	42.5						
72 months		-	-	-	-							
84 months		-	-	-	-							
96 months		-	-	-	-							
108 months		-	-	-	-							
Position at 30 June 2014		-	-	-	-	41.7	48.5	59.2	67.0	63.7		
Marine												
12 months		82.6	57.2	57.8	69.0	55.9	50.7	55.2	55.9	57.1		
24 months		80.2	43.0	60.2	65.1	52.0	49.6	48.0	46.0			
36 months		70.6	33.1	50.6	59.0	45.3	43.8	40.1				
48 months		68.6	29.4	48.2	62.7	41.7	42.3					
60 months		66.4	29.1	49.6	62.5	41.4						
72 months		64.5	26.7	50.3	58.9							
84 months		63.7	26.6	47.0								
96 months		63.3	26.0									
108 months		63.3										
Position at 30 June 2014		63.0	25.6	45.8	55.8	42.0	42.1	36.7	41.3	57.8		
Political risks & contingency												
12 months		61.1	57.6	57.2	57.5	61.1	61.4	58.9	62.6	57.3		
24 months		38.2	36.2	39.2	66.4	38.7	40.3	38.5	42.5			
36 months		28.6	33.0	56.5	72.5	36.0	32.9	33.9				
48 months		25.1	43.2	52.9	86.3	31.2	23.9					
60 months		18.2	39.1	53.8	71.4	25.4						
72 months		17.8	38.8	50.0	60.6							
84 months		17.8	36.0	47.5								
96 months		12.3	30.5									
108 months		12.3										
Position at 30 June 2014		12.3	29.2	49.2	58.2	19.4	23.2	32.7	44.6	57.3		
Property												
12 months		86.7	58.8	58.6	71.3	54.1	59.1	59.7	55.9	55.5		
24 months		83.7	45.1	56.8	66.3	43.2	62.6	52.0	48.4			
36 months		82.2	44.2	54.6	65.2	38.2	60.6	50.1				
48 months		87.2	51.8	55.3	63.2	37.0	57.8					
60 months		86.5	51.9	58.6	61.7	35.9						
72 months		84.9	51.6	66.9	60.6							
84 months		84.1	50.9	67.1								
96 months		83.3	48.7									
108 months		82.2										
Position at 30 June 2014		81.7	47.9	66.4	60.5	35.4	56.8	49.0	46.2	55.4		

Notes to the condensed consolidated interim financial statements *continued*

for the six months ended 30 June 2014

11 Insurance claims *continued*

Gross ultimate claims	2004 ae	2005	2006	2007	2008	2009	2010	2011	2012	2013	2014	Total
		%	%	%	%	%	%	%	%	%	%	
Reinsurance												
12 months		195.5	52.4	59.7	60.2	60.8	68.2	76.5	62.9	61.0		
24 months		186.9	25.0	26.5	50.9	48.5	154.5	77.5	35.9			
36 months		185.3	24.9	22.1	42.4	40.6	143.2	72.5				
48 months		178.6	23.3	20.1	39.2	40.1	137.9					
60 months		174.8	21.4	19.3	38.8	35.9						
72 months		172.3	21.1	19.1	38.9							
84 months		171.2	21.3	17.6								
96 months		170.7	20.8									
108 months		167.3										
Position at 30 June 2014		167.1	20.8	17.7	38.9	35.2	137.8	71.4	33.6	60.4		
Specialty lines												
12 months		72.2	72.7	72.9	72.2	72.9	74.0	75.8	74.2	73.6		
24 months		72.2	72.8	72.5	72.3	72.9	74.0	75.8	74.2			
36 months		70.0	72.7	72.6	72.1	72.0	73.1	76.6				
48 months		66.5	72.8	72.5	72.1	71.5	73.2					
60 months		63.0	71.1	72.5	71.8	71.6						
72 months		56.2	66.1	72.5	72.0							
84 months		52.5	62.2	72.6								
96 months		49.3	58.7									
108 months		47.7										
Position at 30 June 2014		46.7	57.8	71.5	71.5	70.5	71.7	77.0	74.2	73.4		
Total												
12 months		90.4	63.1	63.6	68.8	62.6	64.9	67.4	64.7	64.2		
24 months		87.7	53.4	59.4	67.5	57.5	73.5	63.1	58.0			
36 months		84.1	51.0	58.2	66.2	53.8	69.6	61.3				
48 months		82.5	52.8	58.6	67.5	52.3	67.7					
60 months		79.5	52.3	59.6	65.6	51.3						
72 months		75.9	49.7	61.4	64.0							
84 months		73.9	47.6	60.5								
96 months		72.0	45.1									
108 months		70.6										
Position at 30 June 2014		70.1	44.4	59.9	63.0	50.3	66.8	60.4	56.8	64.2		
Total ultimate losses (\$m)												
	2,991.6	1,076.4	745.7	1,094.2	1,200.4	1,070.7	1,357.4	1,191.8	1,222.6	1,418.7	1,504.3	14,873.8
Less paid claims (\$m)	(2,866.5)	(1,009.8)	(603.4)	(879.3)	(910.9)	(651.3)	(913.8)	(600.6)	(312.8)	(159.9)	(3.9)	(8,912.2)
Less unearned portion of ultimate losses (\$m)	-	-	-	-	-	-	-	-	(7.0)	(203.4)	(1,312.0)	(1,522.4)
Gross claims liabilities (100% level) (\$m)												
	125.1	66.6	142.3	214.9	289.5	419.4	443.6	591.2	902.8	1,055.4	188.4	4,439.2
Less unaligned share (\$m)	(20.4)	(10.7)	(24.0)	(37.8)	(52.0)	(72.7)	(79.3)	(112.6)	(139.9)	(172.0)	(28.9)	(750.3)
Gross claims liabilities, group share (\$m)												
	104.7	55.9	118.3	177.1	237.5	346.7	364.3	478.6	762.9	883.4	159.5	3,688.9

11 Insurance claims *continued*

Net ultimate claims	2004 ae %	2005 %	2006 %	2007 %	2008 %	2009 %	2010 %	2011 %	2012 %	2013 %	2014 %	Total
Life, accident & health												
12 months		-	-	-	-	51.8	51.7	55.1	57.9	65.4		
24 months		-	-	-	-	50.2	52.1	53.9	64.7			
36 months		-	-	-	-	44.6	51.8	62.5				
48 months		-	-	-	-	44.9	51.0					
60 months		-	-	-	-	44.0						
72 months		-	-	-	-							
84 months		-	-	-	-							
96 months		-	-	-	-							
108 months		-	-	-	-							
Position at 30 June 2014		-	-	-	-	43.3	51.2	62.0	64.1	66.9		
Marine												
12 months		55.6	54.1	55.0	61.3	54.6	52.4	56.2	55.4	56.8		
24 months		49.1	42.4	56.6	57.1	48.5	49.4	48.2	45.9			
36 months		42.8	33.2	49.6	50.9	39.8	44.6	39.7				
48 months		39.7	31.7	46.8	47.9	36.2	42.8					
60 months		39.2	31.2	47.6	47.4	35.9						
72 months		38.1	29.4	47.8	46.9							
84 months		36.7	29.3	45.2								
96 months		36.3	28.7									
108 months		36.4										
Position at 30 June 2014		35.9	28.4	44.2	46.1	36.1	42.7	37.4	41.1	57.6		
Political risks & contingency												
12 months		63.7	56.2	55.4	55.9	58.7	57.4	55.1	59.5	54.8		
24 months		46.7	40.4	39.5	74.1	35.1	37.8	37.3	40.7			
36 months		36.2	37.4	55.2	74.7	33.1	30.4	32.1				
48 months		30.3	46.9	53.7	79.2	28.5	21.6					
60 months		24.3	41.2	52.1	68.0	23.0						
72 months		23.2	39.6	48.9	57.8							
84 months		23.2	39.7	46.8								
96 months		15.3	36.8									
108 months		15.3										
Position at 30 June 2014		15.4	35.1	48.0	55.4	18.1	21.0	30.6	41.3	54.8		
Property												
12 months		65.0	61.6	61.3	67.5	53.8	59.1	60.7	58.8	56.9		
24 months		62.3	50.0	59.9	67.5	48.9	66.6	58.1	53.5			
36 months		58.7	48.5	59.1	65.2	45.6	67.0	54.8				
48 months		61.4	52.4	59.6	64.2	43.4	61.1					
60 months		62.0	51.5	62.6	63.2	42.7						
72 months		60.2	51.5	62.7	61.8							
84 months		59.3	51.2	62.7								
96 months		59.3	49.5									
108 months		57.8										
Position at 30 June 2014		57.3	49.0	63.0	61.5	42.1	60.4	52.1	51.9	57.9		

Notes to the condensed consolidated interim financial statements *continued*

for the six months ended 30 June 2014

11 Insurance claims *continued*

Net ultimate claims	2004 ae	2005	2006	2007	2008	2009	2010	2011	2012	2013	2014	Total
		%	%	%	%	%	%	%	%	%	%	
Reinsurance												
12 months		152.9	54.4	55.3	67.1	55.6	77.0	85.6	67.1	58.6		
24 months		131.2	36.5	30.5	56.3	52.4	140.1	87.7	42.8			
36 months		126.8	34.7	25.4	47.5	46.6	135.1	82.5				
48 months		117.3	32.5	22.9	45.5	46.1	130.5					
60 months		111.1	31.1	22.4	44.9	41.2						
72 months		109.9	31.1	22.2	45.0							
84 months		104.7	31.4	20.5								
96 months		104.2	30.7									
108 months		99.3										
Position at 30 June 2014		99.1	30.7	20.5	45.0	40.4	129.4	81.1	40.0	58.6		
Specialty lines												
12 months		69.4	68.7	69.7	70.2	70.1	71.5	72.9	71.5	69.7		
24 months		69.4	68.6	68.7	70.3	70.0	71.4	72.9	71.0			
36 months		67.7	68.7	68.8	70.3	69.3	70.8	72.0				
48 months		64.1	68.7	67.5	68.9	66.2	69.7					
60 months		59.0	64.0	67.4	68.4	66.0						
72 months		53.9	57.9	67.5	68.3							
84 months		50.5	54.4	67.6								
96 months		48.1	51.1									
108 months		46.1										
Position at 30 June 2014		45.1	50.5	67.4	68.4	65.8	68.9	69.7	71.1	69.5		
Total												
12 months		73.2	62.3	63.1	66.3	60.4	64.6	66.9	64.2	62.5		
24 months		68.9	54.7	59.3	66.7	57.0	70.6	63.8	58.0			
36 months		65.1	52.0	58.8	64.3	53.6	68.3	60.9				
48 months		62.4	52.7	57.7	63.3	50.9	65.4					
60 months		59.3	50.5	58.3	61.8	49.8						
72 months		56.4	47.5	58.1	60.6							
84 months		53.9	46.0	57.4								
96 months		52.3	43.9									
108 months		50.6										
Position at 30 June 2014		50.0	43.3	57.2	60.2	49.3	64.9	58.8	56.7	62.9		
Total ultimate losses (\$m)	1,907.8	602.0	592.8	897.4	948.4	817.7	1,125.7	956.9	985.5	1,160.7	1,235.5	11,230.4
Less paid claims (\$m)	(1,800.5)	(551.0)	(493.1)	(746.2)	(769.6)	(561.3)	(793.4)	(540.9)	(290.2)	(144.8)	(3.9)	(6,694.9)
Less unearned portion of ultimate losses (\$m)	-	-	-	-	-	-	-	-	(2.1)	(164.8)	(1,081.1)	(1,248.0)
Net claims liabilities (100% level) (\$m)	107.3	51.0	99.7	151.2	178.8	256.4	332.3	416.0	693.2	851.1	150.5	3,287.5
Less unaligned share (\$m)	(20.4)	(9.7)	(18.9)	(27.9)	(34.0)	(48.7)	(52.5)	(79.0)	(110.3)	(136.2)	(21.3)	(558.9)
Net claims liabilities, group share (\$m)	86.9	41.3	80.8	123.3	144.8	207.7	279.8	337.0	582.9	714.9	129.2	2,728.6

11 Insurance claims *continued*

Analysis of movements in loss development tables

We have updated our loss development tables to show the interim ultimate loss ratios as at 30 June 2014 for each underwriting year. As such, care should be taken when comparing these half year movements to the full year movements shown within the body of each table.

The reserves established in respect of the 2010, 2011 and 2012 catastrophe events remain appropriate in light of development to date.

Life, accident & health

The 2011 and 2012 underwriting years have remained stable after previous strengthening.

Marine

There has been a reduction in most net ultimate loss ratios, in particular the 2011 and 2012 underwriting years. This is due to the continuing benign claims experience. The 2009 underwriting year saw a slight increase in ultimate loss ratio with the deterioration of a claim on the hull class of business, while the net ultimate loss ratio on 2013 increased due to a slight deterioration on the downhole class of business.

Political risks & contingency

The 2004 and 2009 underwriting years have seen improvements in claims position within the political book. Concurrently the 2007 and 2012 underwriting years were subject to slight deteriorations on trade credit-related claims.

Property

There have been positive developments across most underwriting years, driven by reserve releases on previous natural catastrophes, favourable attritional experience and benign natural catastrophe experience.

Reinsurance

The 2011 underwriting year saw a small reduction in net ultimate loss ratio as the ultimate claims estimate for the Thailand Floods event was reduced. The 2012 underwriting year has improved with release of catastrophe margin as exposure is run off.

Specialty lines

Releases from the 2003 to 2006 underwriting years have continued, with more recent underwriting years remaining stable.

Notes to the condensed consolidated interim financial statements *continued*

for the six months ended 30 June 2014

11 Insurance claims *continued*

Claims releases

The table below analyses our net insurance claims between current year claims and adjustments to prior year net claims reserves. These have been broken down by segment and period.

The net of reinsurance claims release on 2013 and prior underwriting years has risen to \$72.9m (2013: \$60.8m). The releases are the result of both generally favourable development and recoveries on specific claims.

The movements shown on 2011 and earlier are absolute claim movements and are not impacted by any current year movements on premium on those underwriting years.

	Life accident & health \$m	Marine \$m	Political risks & contingency \$m	Property \$m	Reinsurance \$m	Specialty lines \$m	Total \$m
6 months ended 30 June 2014							
Current year	27.2	73.5	24.4	83.6	46.3	229.1	484.1
Prior year							
- 2011 and earlier	(0.9)	(11.4)	(10.7)	(11.0)	(5.9)	(15.3)	(55.2)
- 2012 underwriting year	(0.2)	(10.4)	1.4	(5.6)	(3.8)	(1.3)	(19.9)
- 2013 underwriting year	0.4	0.5	(0.1)	1.8	(0.4)	-	2.2
	(0.7)	(21.3)	(9.4)	(14.8)	(10.1)	(16.6)	(72.9)
Net insurance claims	26.5	52.2	15.0	68.8	36.2	212.5	411.2

	Life accident & health \$m	Marine \$m	Political risks & contingency \$m	Property \$m	Reinsurance \$m	Specialty lines \$m	Total \$m
6 months ended 30 June 2013							
Current year	29.5	74.2	25.8	83.3	32.2	211.9	456.9
Prior year							
- 2010 and earlier	(0.9)	(2.9)	(9.2)	(4.2)	(1.3)	(17.9)	(36.4)
- 2011 underwriting year	4.9	(14.1)	(1.0)	(3.0)	(3.9)	-	(17.1)
- 2012 underwriting year	0.7	-	-	1.7	(9.7)	-	(7.3)
	4.7	(17.0)	(10.2)	(5.5)	(14.9)	(17.9)	(60.8)
Net insurance claims	34.2	57.2	15.6	77.8	17.3	194.0	396.1

	Life accident & health \$m	Marine \$m	Political risks & contingency \$m	Property \$m	Reinsurance \$m	Specialty lines \$m	Total \$m
Year to 31 December 2013							
Current year	66.2	136.0	44.1	155.9	85.1	449.8	937.1
Prior year							
- 2010 and earlier	(1.4)	(14.8)	(27.8)	(18.9)	(18.4)	(43.4)	(124.7)
- 2011 underwriting year	7.0	(21.4)	(3.8)	(8.0)	(9.6)	(3.2)	(39.0)
- 2012 underwriting year	(1.0)	(11.1)	(7.8)	(6.8)	(27.6)	-	(54.3)
	4.6	(47.3)	(39.4)	(33.7)	(55.6)	(46.6)	(218.0)
Net insurance claims	70.8	88.7	4.7	122.2	29.5	403.2	719.1

12 Related party transactions

The nature of the related party transactions of the group are consistent in nature and scope with those disclosed in note 30 of the group's consolidated financial statements for the year ended 31 December 2013.

During the six months ended 30 June 2014, Beazley invested an additional \$1.6m in its associate company Capson Corp., Inc.

During 2013, the company impaired its investment in Falcon Money Management Holdings Limited due to uncertainty over the future revenues of the investee. In June 2014, Beazley plc received from Falcon Money Management Holdings Limited a commitment to return \$1.5m on the original investment and this has been recognised in the statement of profit or loss. The investment does not relate to a specific reportable segment and, as such, the reversal of the impairment loss has been allocated to all reportable segments.

There were no other transactions with related parties during the period which have had a material effect on the results or financial position of the group.

13 Foreign exchange rates

The group used the following exchange rates to translate foreign currency assets, liabilities, income and expenses into US dollars, being the group's presentation currency:

	6 months ended 30 June 2014	6 months ended 30 June 2013	Year to 31 December 2013
Average			
Pound sterling	0.60	0.65	0.64
Canadian dollar	1.10	1.02	1.03
Euro	0.73	0.77	0.76
Spot			
Pound sterling	0.58	0.66	0.60
Canadian dollar	1.06	1.05	1.06
Euro	0.73	0.77	0.72

14 Subsequent events

There are no events that are material to the operations of the group that have occurred since the reporting date.

Responsibility statement of the directors in respect of the interim report

We confirm that to the best of our knowledge:

- the condensed consolidated financial statements has been prepared in accordance with IAS 34 Interim Financial Reporting as adopted by the EU;
- the interim management report includes a fair review of the information required by:
 - (a) DTR 4.2.7R of the Disclosure and Transparency Rules, being an indication of important events that have occurred during the first six months of the financial year and their impact on the condensed set of financial statements; and a description of the principal risks and uncertainties for the remaining six months of the year; and
 - (b) DTR 4.2.8R of the Disclosure and Transparency Rules, being related party transactions that have taken place in the first six months of the current financial year and that have materially affected the financial position or performance of the entity during that six months; and any changes in the related party transactions described in the last annual report that could do so.

Martin Bride
Finance director

21 July 2014

Independent review report to Beazley plc

Introduction

We have been engaged by Beazley plc ('the company') to review the condensed consolidated set of financial statements in the interim report for the six months ended 30 June 2014 ('interim report') which comprises the consolidated statement of profit or loss, consolidated statement of comprehensive income, consolidated statement of changes in equity, consolidated statement of financial position, consolidated statement of cash flows and the related explanatory notes. We have read the other information contained in the interim report and considered whether it contains any apparent misstatements or material inconsistencies with the information in the condensed consolidated set of financial statements.

This report is made solely to the company in accordance with the terms of our engagement to assist the company in meeting the requirements of the Disclosure and Transparency Rules ('the DTR') of the UK's Financial Conduct Authority ('the UK FCA'). Our review has been undertaken so that we might state to the company those matters we are required to state to it in this report and for no other purpose. To the fullest extent permitted by law, we do not accept or assume responsibility to anyone other than the company for our review work, for this report, or for the conclusions we have reached.

Directors' responsibilities

The interim report is the responsibility of, and has been approved by, the directors. The directors are responsible for preparing the interim report in accordance with the DTR of the UK FCA.

As disclosed, the annual financial statements of the Group are prepared in accordance with IFRSs as adopted by the EU. The directors are responsible for ensuring that the condensed consolidated set of financial statements included in this interim report has been prepared in accordance with IAS 34 Interim Financial Reporting as adopted by the EU.

Our responsibility

Our responsibility is to express to the company a conclusion on the condensed set of consolidated financial statements in the interim report based on our review.

Scope of review

We conducted our review in accordance with International Standard on Review Engagements (UK and Ireland) 2410 Review of Interim Financial Information Performed by the Independent Auditor of the Entity issued by the Auditing Practices Board. A review of interim financial information consists of making enquiries, primarily of persons responsible for financial and accounting matters, and applying analytical and other review procedures. A review is substantially less in scope than an audit conducted in accordance with International Standards on Auditing (UK and Ireland) and consequently does not enable us to obtain assurance that we would become aware of all significant matters that might be identified in an audit. Accordingly, we do not express an audit opinion.

Conclusion

Based on our review, nothing has come to our attention that causes us to believe that the condensed consolidated set of financial statements in the interim report for the six months ended 30 June 2014 is not prepared, in all material respects, in accordance with IAS 34 as adopted by the EU and the DTR of the UK FCA.

Hubert Crehan

For and on behalf of

KPMG

Chartered Accountants and Recognised Auditors

1 Harbourmaster Place

International Financial Services Centre

Dublin 1, Ireland

21 July 2014

Glossary

Aggregates/aggregations

Accumulations of insurance loss exposures which result from underwriting multiple risks that are exposed to common causes of loss.

Aggregate excess of loss

The reinsurer indemnifies an insurance company (the reinsured) for an aggregate (or cumulative) amount of losses in excess of a specified aggregate amount.

A.M. Best

A.M. Best is a worldwide insurance-rating and information agency whose ratings are recognised as an ideal benchmark for assessing the financial strength of insurance related organisations, following a rigorous quantitative and qualitative analysis of a company's balance sheet strength, operating performance and business profile.

Binding authority

A contracted agreement between a managing agent and a coverholder under which the coverholder is authorised to enter into contracts of insurance for the account of the members of the syndicate concerned, subject to specified terms and conditions.

Capacity

This is the maximum amount of premiums that can be accepted by a syndicate. Capacity also refers to the amount of insurance coverage allocated to a particular policyholder or in the marketplace in general.

Capital growth assets

These are assets that do not pay a regular income and target an increase in value over the long-term. They will typically have a higher risk and volatility than that of the core portfolio. Currently these are the hedge fund and regulated equity linked fund assets.

Catastrophe reinsurance

A form of excess of loss reinsurance which, subject to a specified limit, indemnifies the reinsured company for the amount of loss in excess of a specified retention with respect to an accumulation of losses resulting from a catastrophic event or series of events.

Claims

Demand by an insured for indemnity under an insurance contract.

Claims ratio

Ratio, in percentage terms, of net insurance claims to net earned premiums. The calculation is performed excluding the impact of foreign exchange.

Combined ratio

Ratio, in percentage terms, of the sum of net insurance claims, expenses for acquisition of insurance contracts and administrative expenses to net earned premiums. This is also the sum of the expense ratio and the claims ratio. The calculation is performed excluding the impact of foreign exchange.

Coverholder/managing general agent

A firm either in the United Kingdom or overseas authorised by a managing agent under the terms of a binding authority to enter into contracts of insurance in the name of the members of the syndicate concerned, subject to certain written terms and conditions. A Lloyd's broker can act as a coverholder.

Deferred acquisition costs (DAC)

Costs incurred for the acquisition or the renewal of insurance policies (e.g. brokerage, premium levy and staff related costs) which are capitalised and amortised over the term of the contracts.

Earnings per share (EPS) – basic/diluted

Ratio, in pence and cents, calculated by dividing the consolidated profit after tax by the weighted average number of ordinary shares issued, excluding shares owned by the group. For calculating diluted earnings per share the number of shares and profit or loss for the year is adjusted for certain dilutive potential ordinary shares such as share options granted to employees.

Economic Capital Requirement (ECR)

The level of capital required by the syndicate's members to support their underwriting. Calculated as the uSCR 'uplifted' by 35% to ensure capital is in place to support Lloyd's ratings and financial strength.

Excess per risk reinsurance

A form of excess of loss reinsurance which, subject to a specified limit, indemnifies the reinsured company against the amount of loss in excess of a specified retention with respect to each risk involved in each loss.

Expense ratio

Ratio, in percentage terms, of the sum of expenses for acquisition of insurance contracts and administrative expenses to net earned premiums. The calculation is performed excluding the impact of foreign exchange on non-monetary items.

Facultative reinsurance

A reinsurance risk that is placed by means of a separately negotiated contract as opposed to one that is ceded under a reinsurance treaty.

Gross premiums written

Amounts payable by the insured, excluding any taxes or duties levied on the premium, including any brokerage and commission deducted by intermediaries.

Hard market

An insurance market where prevalent prices are high, with restrictive terms and conditions offered by insurers.

Horizontal Limits

Reinsurance coverage limits for multiple events.

Incurred but not reported (IBNR)

These are anticipated or likely claims that may result from an insured event although no claims have been reported so far.

International accounting standards board (IASB)

An independent accounting body responsible for developing IFRS.

International accounting standards (IAS)/**International financial reporting standards (IFRS)**

Standards formulated by the IASB with the intention of achieving internationally comparable financial statements. Since 2002, the standards adopted by the IASB have been referred to as International Financial Reporting Standards (IFRS). Until existing standards are renamed, they continue to be referred to as International Accounting Standards (IAS).

Lead underwriter

The underwriter of a syndicate who is responsible for setting the terms of an insurance or reinsurance contract that is subscribed by more than one syndicate and who generally has primary responsibility for handling any claims arising under such a contract.

Line

The proportion of an insurance or reinsurance risk that is accepted by an underwriter or which an underwriter is willing to accept.

Managing agent

A company that is permitted by Lloyd's to manage the underwriting of a syndicate.

Managing general agent (MGA)

An insurance intermediary acting as an agent on behalf of an insurer.

Medium tail

A type of insurance where the claims may be made a few years after the period of insurance has expired.

Net assets per share

Ratio, in pence and cents, calculated by dividing the net assets (total equity) by the number of shares issued.

Net premiums written

Net premiums written is equal to gross premiums written less outward reinsurance premiums written.

Provision for outstanding claims

Provision for claims that have already been incurred at the reporting date but have either not yet been reported or not yet been fully settled.

Rate

The premium expressed as a percentage of the sum insured or limit of indemnity.

Reinsurance special purpose syndicate

A special purpose syndicate (SPS) created to operate as a reinsurance 'sidecar' to Beazley's treaty account, capitalising on Beazley's position in the treaty reinsurance market.

Reinsurance to close (RITC)

A reinsurance which closes a year of account by transferring the responsibility for discharging all the liabilities that attach to that year of account (and any year of account closed into that year) plus the right to buy any income due to the closing year of account into an open year of account in return for a premium.

Retention limits

Limits imposed upon underwriters for retention of exposures by the group after the application of reinsurance programmes.

Return on equity (ROE)

Ratio, in percentage terms calculated by dividing the consolidated profit after tax by the average daily total equity.

Retrocessional reinsurance

The reinsurance of the reinsurance account. It serves to 'lay-off' risk.

Risk

This term may variously refer to:

- a) the possibility of some event occurring which causes injury or loss;
- b) the subject matter of an insurance or reinsurance contract; or
- c) an insured peril.

Special purpose syndicate

Specialty reinsurance company designed to provide additional capacity to a specific insurance company. They operate by purchasing a portion or all of a group of insurance policies, typically cat exposures. They have become quite prominent in the aftermath of Hurricane Katrina as a vehicle to add risk-bearing capacity, and for investors to participate in the potential profits resulting from sharp price increases.

Short tail

A type of insurance where claims are usually made during the term of the policy or shortly after the policy has expired. Property insurance is an example of short-tail business.

Soft market

An insurance market where prevalent prices are low, and terms and conditions offered by insurers are less restrictive.

Solvency Capital Requirement on an ultimate basis (uSCR)

The capital requirement under solvency II calculated by Beazley's internal model which captures the risk in respect of the planned underwriting for the prospective year of account in full covering ultimate adverse development and all exposures.

Surplus lines insurer

An insurer that underwrites surplus lines insurance in the USA. Lloyd's underwriters are surplus lines insurers in all jurisdictions of the USA except Kentucky and the US Virgin Islands.

Total shareholder return (TSR)

The increase in the share price plus the value of any first and second dividends paid and proposed during the year.

Treaty reinsurance

A reinsurance contract under which the reinsurer agrees to offer and to accept all risks of certain size within a defined class.

Unearned premiums reserve

The portion of premium income in the business year that is attributable to periods after the balance date is accounted for as unearned premiums in the underwriting provisions.

Company information

Directors

George P Blunden*
Martin L Bride (Finance director)
Adrian P Cox
Angela Crawford-Ingle*
Dennis Holt* (Chairman)
D Andrew Horton (Chief executive)
Neil P Maidment
Padraic J O'Connor*
Vincent J Sheridan*
Ken P Sroka*
Rolf A W Tolle*
Clive A Washbourn

* non-executive director

Company Secretary

Sian Coope

Registered office

22 Grenville Street
St Helier
Jersey JE4 8PX

Registered Number

102680

Auditors

KPMG
1 Harbourmaster Place
IFSC
Dublin 1

If you have finished reading this report and no longer wish to keep it, please pass it on to other interested readers, return it to Beazley or recycle it. Thank you.

*Designed and produced by:
Instinctif Partners www.instinctif.com*

*Beazley online Interim report 2014
www.reports.beazley.com/2014-interim*



Beazley plc

2 Northwood Avenue
Northwood Park
Santry Demesne
Santry
Dublin 9 | Ireland

Phone: +353 (0)1 854 4700
Fax: +353 (0)1 842 8481

Registered number: 102680

www.beazley.com

beazley